

SUBMITTAL DATA: MSZ-FE18NA & MUZ-FE18NA
18,000 BTU/H WALL-MOUNTED HEAT PUMP SYSTEM

Job Name:

System Reference:

Date:



GENERAL FEATURES

- Highly energy-efficient system with quiet operation
- Updated sleek, compact indoor unit design
- Includes Nano Platinum and Anti-allergy Enzyme filters
- “Powerful Mode” function permits system to temporarily run at a lower/higher temperature with an increased fan speed, which quickly brings the room to the optimum comfort level
- Hand-held Wireless Remote Controller
- Limited warranty: five years parts and seven years compressors

ACCESSORIES

Outdoor Unit

- Base Heater (MAC-642BH-U)
- Three-pole Disconnect Switch (TAZ-MS303)
- Air Outlet Guide (MAC-886SG-E)
- Mounting Base (DSD-400N)
- Mounting Pad (ULTRILITE1)
- Drain Socket Assembly (MAC-860DS)

Indoor Unit

- Condensate Pump (SI3100-230; 230V)
- Replacement Anti-allergy Enzyme Filters (MAC-2310FT-E; 2/set)

Controller Options

- Wireless Wall-mounted Remote Controller Kit (MHK1)*
 - Portable Central Controller (MCCH1)*
 - Outdoor Air Sensor (MOS1)*
 - Wired Wall-mounted Controller (PAR-31MAA requires MAC-333IF)*
 - Simple MA Remote Controller (PAC-YT53CRAU requires MAC-333IF)*
- *See Submittal for information on each option.
- System Control Interface (MAC-333IF)
 - Remote Temperature Sensor (M21-JKO-307)
 - Lockdown Bracket for Hand-held Controller (RCMKP1CB)



SPECIFICATIONS : MSZ-FE18NA & MUZ-FE18NA

Cooling*

Rated Capacity18,000 Btu/h
 Minimum to Maximum Capacity Range8,200 - 25,200 Btu/h
 SEER20.2 Btu/h/W
 EER14.2 Btu/h/W
 Total Rated Input1,270 W

Heating at 47° F*

Rated Capacity21,600 Btu/h
 Minimum to Maximum Capacity Range7,500 - 29,700 Btu/h
 HSPF10.3 Btu/h/W
 COP4.11
 Total Rated Input1,540 W

Heating at 17° F*

Rated Capacity11,700 Btu/h
 Rated Total Input1,240 W
 COP2.77
 Maximum Capacity**21,600 Btu/h
 Maximum Total Input2,620 W

Heating at 5° F*

Maximum Capacity**21,600 Btu/h

*** Rating Conditions per AHRI Standard**

Cooling | Indoor: 80° F (27° C) DB / 67° F (19° C) WB
 Cooling | Outdoor: 95° F (35° C) DB / 75° F (24° C) WB
 Heating at 47° F | Indoor: 70° F (21° C) DB / 60° F (16° C) WB
 Heating at 47° F | Outdoor: 47° F (8° C) DB / 43° F (6° C) WB
 Heating at 17° F | Indoor: 70° F (21° C) DB / 60° F (16° C) WB
 Heating at 17° F | Outdoor: 17° F (-8° C) DB / 15° F (-9° C) WB
 Heating at 5° F | Indoor: 70° F (21° C) DB / 60° F (16° C) WB
 Heating at 5° F | Outdoor: 5° F (-15° C) DB / 5° F (-15° C) WB

**Maximum Capacity is at full speed and performance for INVERTER-driven System.

Electrical Requirements

Power Supply208 / 230V, 1-Phase, 60 Hz
 Breaker Size20 A

Voltage

Indoor - Outdoor S1-S2AC 208 / 230V
 Indoor - Outdoor S2-S3DC +/- 24V
 Indoor - Remote Controller.....MHK1 DC 3V
 PAR-31MAA DC 12V
 PAC-YT53CRAU DC 12V

OPERATING CONDITIONS

		Indoor Intake Air Temp.	Outdoor Intake Air Temp.
Cooling	Maximum	90° F (32° C) DB 73° F (23° C) WB	115° F (46° C) DB
	Minimum	67° F (19° C) DB 57° F (14° C) WB	14° F (-10° C) DB
Heating	Maximum	80° F (27° C) DB 67° F (19° C) WB	75° F (24° C) DB 65° F (18° C) WB
	Minimum	70° F (21° C) DB 60° F (16° C) WB	-13° F (-25° C) DB -15° F (-26° C) WB**

** System cuts out at -18° F (-28° C) to avoid thermistor error, but recovers from cutout operation and automatically restarts at -13° F (-25° C).

Indoor Unit

MCA1 A
 Blower Motor (ECM)0.76 F.L.A.
Airflow
 Cooling (Lo - Med - Hi - Powerful) ...388 - 469 - 628 - 738 Dry CFM
 347 - 420 - 562 - 661 Wet CFM
 Heating (Lo - Med - Hi - Powerful) ...388 - 469 - 628 - 738 Dry CFM
Sound Pressure Level
 Cooling (Lo - Med - Hi - Powerful)34 - 41 - 49 - 53 dB(A)
 Heating (Lo - Med - Hi - Powerful)32 - 41 - 49 - 52 dB(A)

DIMENSIONS	UNIT INCHES / MM
W	43-5/16 / 1,116
D	9-3/8 / 238
H	12-13/16 / 325

Weight37 lbs. / 17 kg
 Moisture Removal.....2.7 pt./h
 External FinishMunsell No. 1.0Y 9.2 / 0.2
 Field Drainpipe Size O.D.....5/8" / 15.88 mm

Outdoor Unit

CompressorDC Inverter-driven Twin Rotary
 MCA17.1 A
 Fan Motor (ECM)0.93 F.L.A.
Sound Pressure Level
 Cooling55 dB(A)
 Heating55 dB(A)

DIMENSIONS	INCHES / MM
W	33-1/16 + 3-3/16 / 840 + 81
D	13 / 330
H	34-5/8 / 880

Weight119 lbs. / 54 kg
 External FinishMunsell No. 3.0Y 7.8 / 1.1
 Refrigerant TypeR410A
 Refrigerant Pipe Size O.D.
 Gas Side5/8" / 15.88 mm
 Liquid Side3/8" / 6.35 mm
 Max. Refrigerant Pipe Length.....100' / 30 m
 Max. Refrigerant Pipe Height Difference50' / 15 m
 Connection MethodFlared

Notes:

DIMENSIONS: MSZ-FE18NA & MUZ-FE18NA

MSZ-FE18NA

Unit: inch

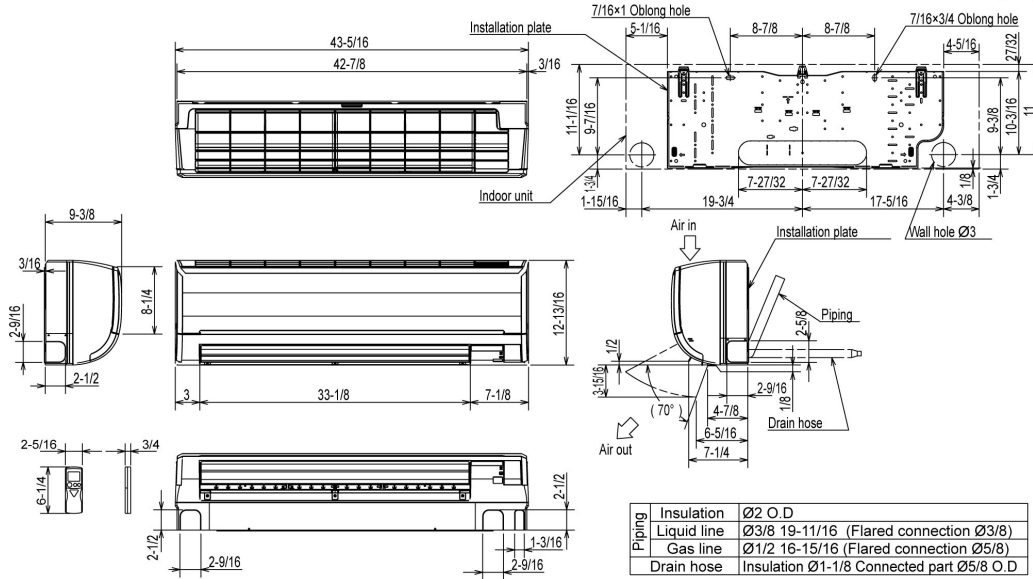

MUZ-FE18NA

Unit: inch

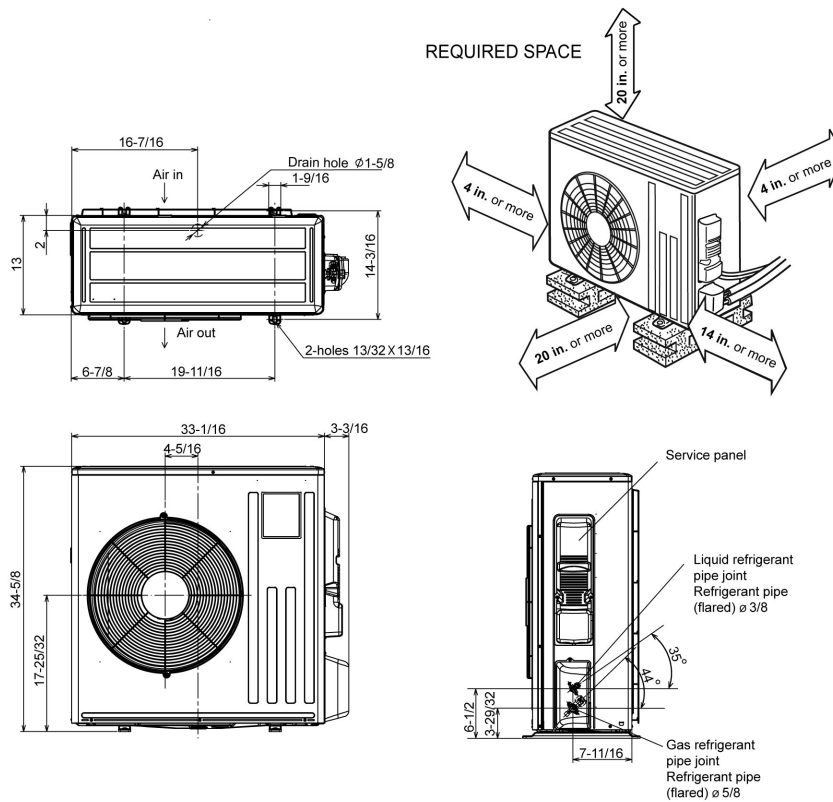

Intertek



COOLING & HEATING

1340 Satellite Boulevard
Suwanee, GA 30024
Toll Free: 800-433-4822
www.mehvac.com